

Hydraulic Steering System For Outboard Engine

Manual for Owner, Installer

MO 100H



SEAFIRST
ENGINEERING

Seafirst Engineering Co
137, Tekeunobaelli-ro, Jillye-myeon, Gimhae-si,
Gyeongsangnam-do, Korea
Tel : 82 55 338 1640 Fax : 82 55 338 1641
<http://www.seafirst.co.kr>
Manual Version : SCSM-100H-Ver.1

CONTENTS

General	3
Operating Instruction	4
Order Guide	5
1. Packaged system : MO 100H	
Installation	6
1. Helm pump	
2. Cylinder	
3. Test Procedures	
4. Oil Filling and Bleeding	
System Diagram	17
1. Single Engine	
Maintenance & Cleaning	19

1. Introduction

On board the boat, correct operation and handling according to this manual is essential at any time to assure the safety and the proper function. Incorrect operation and /or handling without fully understanding the contents of the manual can cause irreparable damage or fatal accident in the worst case. Read this manual carefully to have good understanding on the contents before setting out to sea.

- Read this manual carefully to have good understanding on the contents
- Always bring this manual with you to the boat, and keep it where it is readily available.
- Pay attention that the manual will not be lost or contaminated while not in use.
- In case of resale or transfer of the system, be sure to give this manual to the new owner.
- Please note that the illustration and/or contents of this manual may partly differ from the actual product due to the specification change. Etc.

• Notice to Customers :

Thank you for purchasing Seafirst Outboard steering system.

This manual provides the information for correct installation, operation, maintenance and inspection of the system with cautionary remarks. Please read this manual carefully before starting operation to ensure the correct use of the system.

This system is intended for the installation by a person who has basic understanding and skill in the servicing of hydraulic steering system. Without such knowledge and skill, attempted installation could cause failures or mechanical damages to the system. Please have your system installed by your dealer, if you are not a specialized mechanic.

In the course of boat operation, always keep this manual on board where it would not be lost or get wet. If you transfer or resell this hydraulic steering system, be sure to give this manual to the new owner.

• Notice to Dealers :

Please explain the product and address any cautionary remark to the customer. Make sure that this manual and part of it removed during the installation work be handed over to the customers.

Special attention should be paid for the cylinder installation. Notice to the transom limitation and mechanical interference of the cylinder, its linkage in steering and tilting-up operation

2. Instruction Symbols

CAUTION

CAUTION indicates special precautions that must be taken to avoid damages to the outboard engine

IMPORTANT

IMPORTANT is an importation to proper operation, inspection or maintenance.

Operating Instruction

1. Components and its role

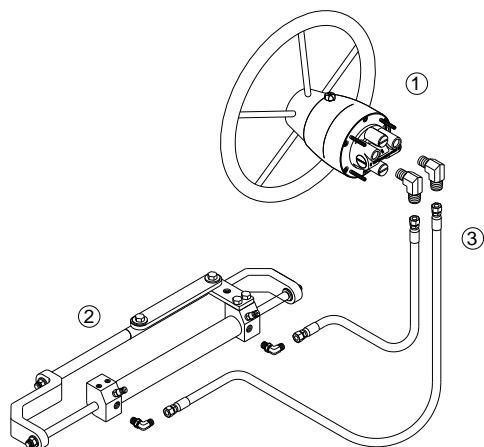

Our hydraulic steering system is consist of as table

Component	Description
1. Helm Pump	The piston pump is designed for manual hydraulic steering. It has inbuilt lock valve.
2. CYLINDER	SOC2512H type is universal installation.
3. Hydraulic Hose	It s path for the oil to flow from the helm pump to the cylinder

2. How it works

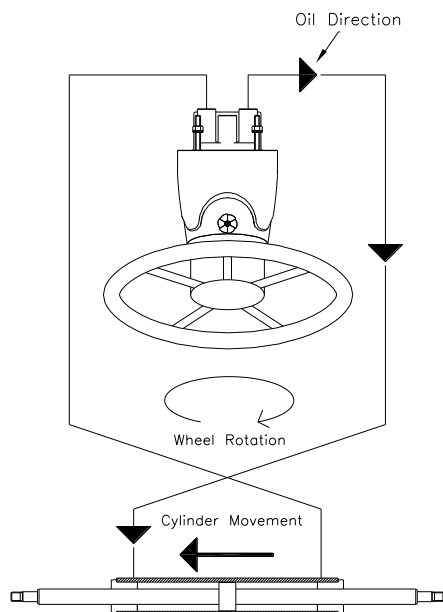

If Steering wheel is rotated in clockwise, oil is pump out from the port (right port from the front view) into the port of cylinder (port side). This cause the cylinder tube move to the port side, which move the boat to right side (starboard) Oil displaced from the opposite end of the cylinder flows back to the helm pump For steering in the opposite direction, simply turn the helm pump the other way When no course corrections are required, the inbuilt lock valve holds the outboard engine stationary

MAXIMUM OPERATING PRESSURE : 80 BAR
RECOMMENDATIONS FOR THREAD SEALANT IF REQUIRED: LOCTITE 572

1. Packaged system

1-1) MO 100H : Complete system for single engine

System Model	Description
MO 100H	Yamaha 4stroke : From 20hp to 90hp Yamaha 2stroke : From 30hp to 95hp Honda 4stroke : From 20hp to 70hp Suzuki 4stroke : From 20hp to 70hp Mercury : From 30hp to 60hp Tohatsu 4stroke : Up to BFT 90hp Tohatsu 2stroke : Up to M 90hp

95HP APPLICABLE

MO 100H type package



*Cylinder based on
SOC 2512H type*

Model	Description
CSH Helm Pump	Front Mount Helm pump 18cc
SOC 2512H CYLINDER	Front Mount Outboard cylinder. When ordering, specify the engine model.
SF OIL 15 Hydraulic Oil	Hydraulic oil 1 liter x 2 bottles. SAE NO 15.
NH 04-SS-07 Hydraulic Hose	1/4" Hydraulic Hose 7 meter x 2pcs
Accessories Included	Helm pump fittings, Helm pump mounting hardware kit, Accessories kit OAK-300 (Bleed tube, Funnel, Oil supply tube)

The Steering Wheel is not included in the package.

1. HELM PUMP

1-1) : SPECIFICATION & FUNCTION

Model	Displacement		Lock valve	Steering Wheel
	cc / rev	cu.in / rev		
CSH	18	1.09	Built-in	Min Dia 260mm

- Maximum durability
- 3 ball bearings supporting the rotar, which make the helm pump be used for heavy duty use.
- SS 304 shaft
- At factory, the two ports on the rear are blocked tightly with black plugs while the two ports are blocked loosely with red plugs for an easy open to connect hydraulic hose fittings.
- Fixed displacement
- Lock Valve Inbuilt
- Mounting Hardware and steering wheel mounting hardware supplied as standard
- Interconnecting ports (black plugs) for dual stations of steering .
- Common dash hole mount for easy replacement with other brand

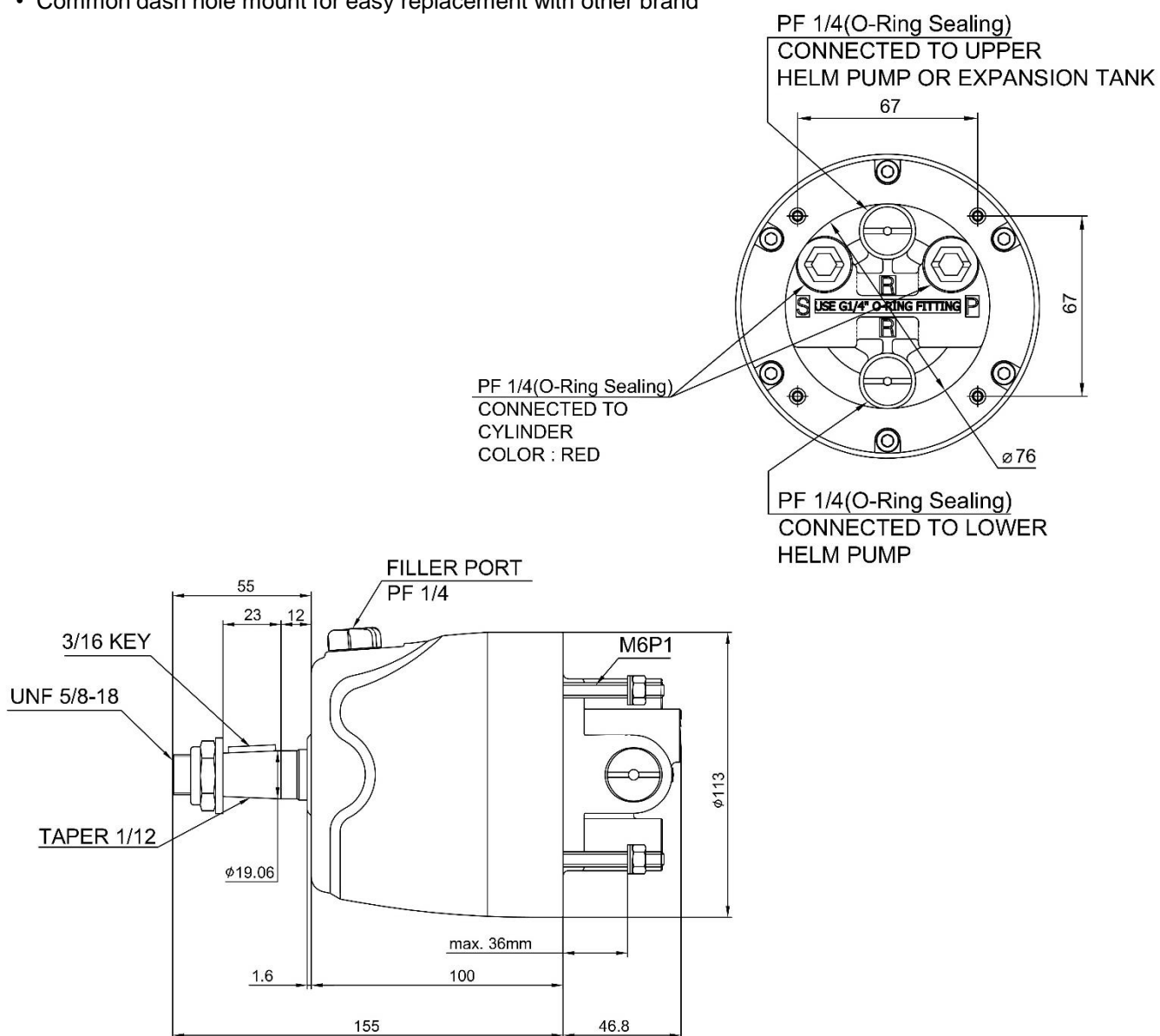

1-2) MOUNTING THE HELM PUMP IN FRONT

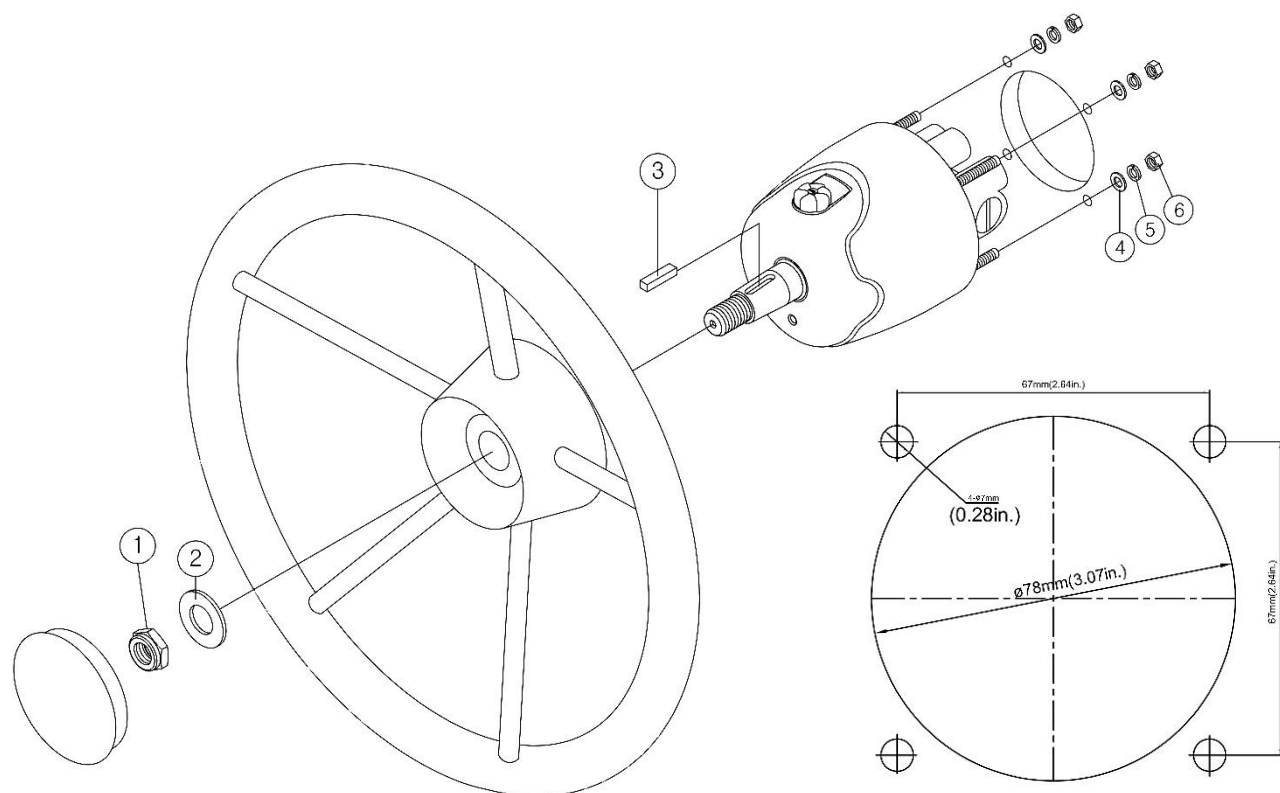

PANEL CUT DIMENSION

Mounting the helm pump (CSH series)

1. To install the pump, cut a hole of diameter 78mm in the dash board (panel).
2. Mark the location of the four holes by using Template supplied additionally
3. Drill 4 holes with Diameter 7mm.
4. Install the helm pump into the hole and tighten the helm pump with 4 x Nuts and Washers supplied as mounting hardware.

Mounting the wheel

1. Make sure that your steering wheel is suitable for 3/16" straight key and taper on 3/4" shaft.
2. Grease the shaft cone and install the wheel on the shaft with key supplied.
3. Tighten the wheel with UNF 5/8-18 Nylon Nut and Plain Washer supplied as mounting hardware.

Mounting Hardware Kit

No	Description	Q'ty	No	Description	Q'ty
1	UNF 5/8-18 Nylon Nut	1	4	Plain Washer M6	4
2	Plain Washer	1	5	Spring Washer M6	4
3	Straight Key 3/16"	1	6	Nut M6	4

2 Cylinder 2-1) Specification

Basic Model : SOC 2512H	
Volume	83cc
Output force	264kg
Shaft diameter	12mm
Bore diameter	25mm
Stroke	220mm

- Stainless steel shaft with hard chrome plate
- Aluminum tube with anodizing
- Aluminum arms with anodizing
- Stainless steel lock nuts
- Compact Design for less space installation
- Install for single and multi engines
- Balanced cylinder : The number of turns lock to lock is equal port to starboard

⚠ CAUTION

Never damage the cylinder rod.
Oil will leak through the rod seals.

SOC 2512H

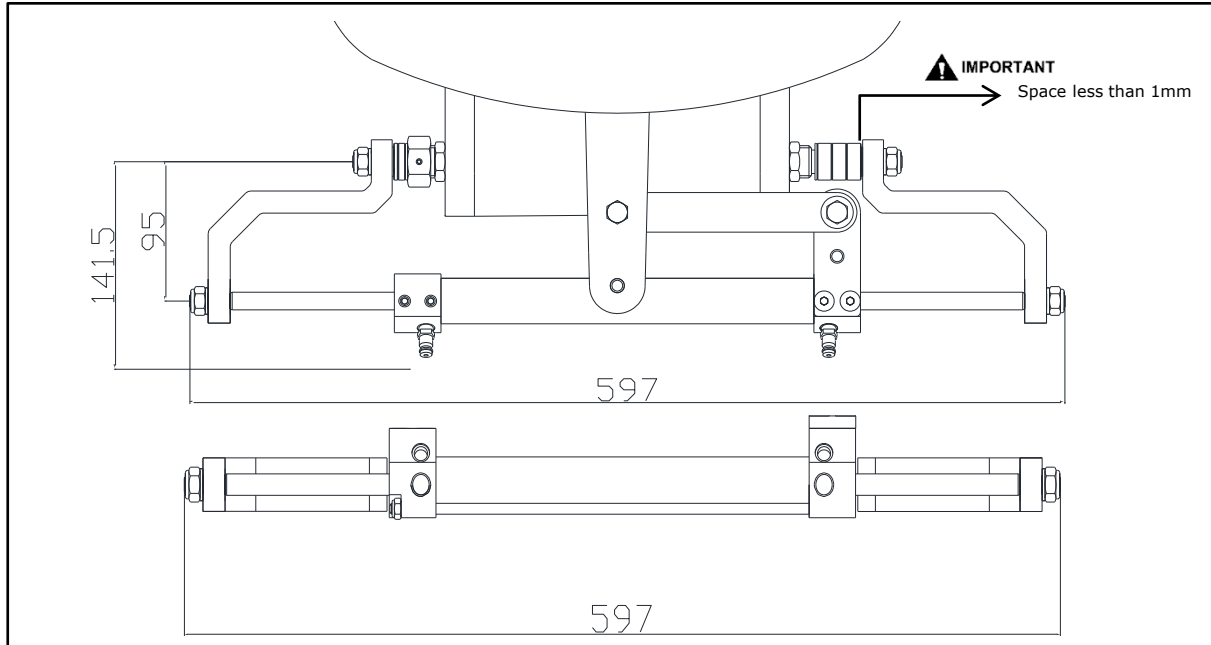

2-2) Dimension of Cylinder

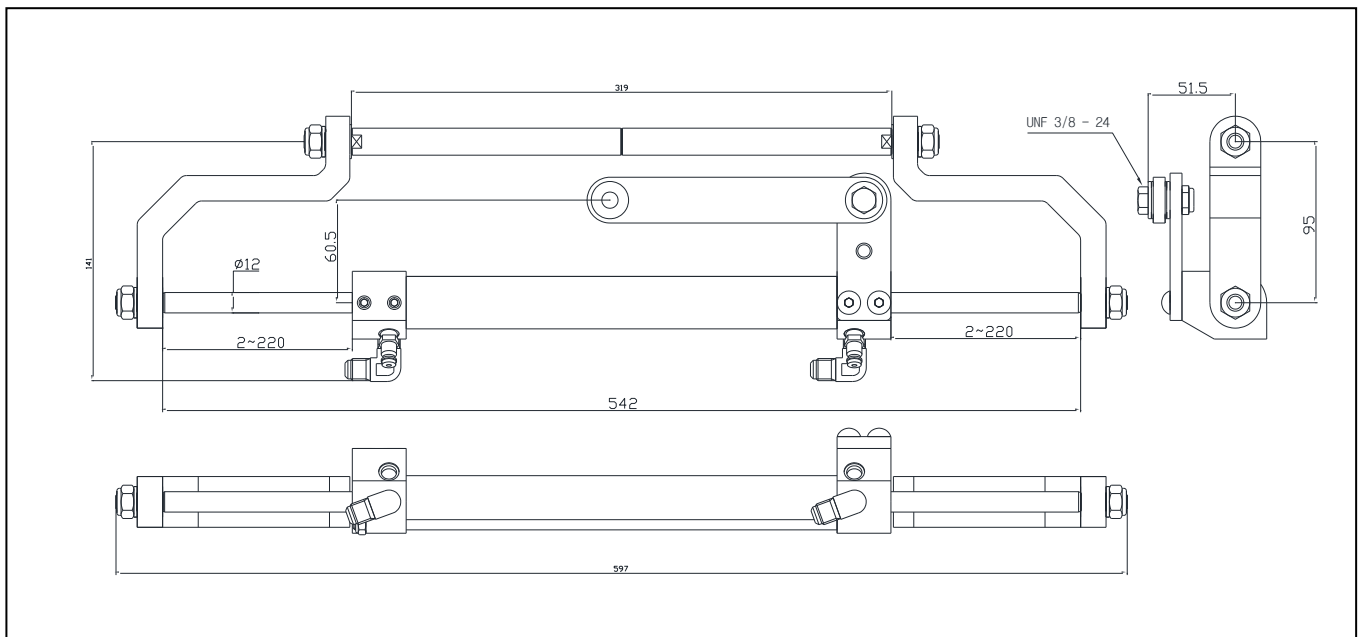

Cylinder model SOC - 2512H

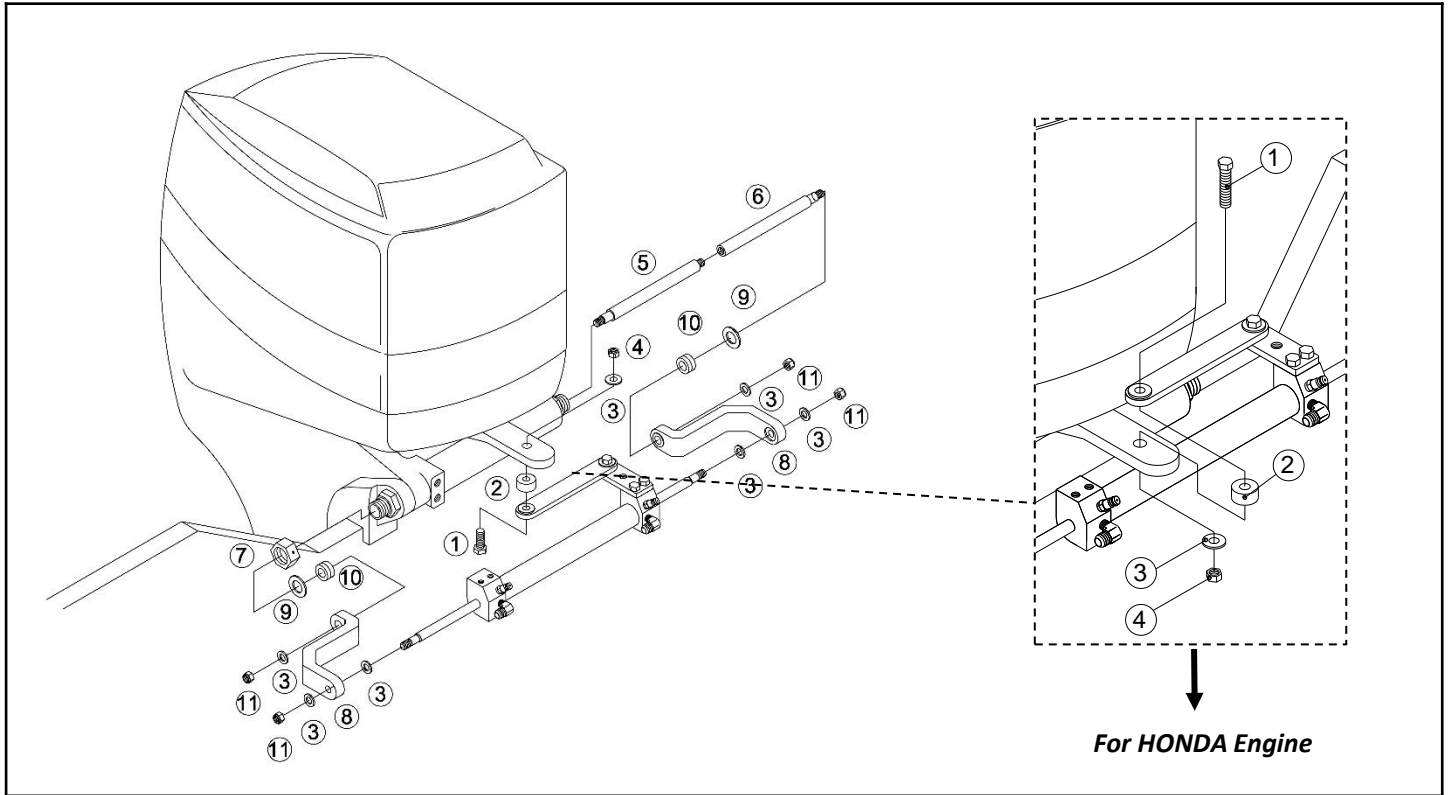

No	Part Number	Q' TY	Description
①	B030824038S	1	Bolt
②	C3520134	1	Spacer
③	PW1019020S	7	Plain Washer
④	NY030824014SS	1	Nylock Nut
⑤	C2512115	1	Support Rod L
⑥	C2512116	1	Support Rod R
⑦	C3520139	1	ADJ. nut
⑧	C2512114	2	Arm
⑨	PW1625015S	2	Plain Washer
⑩	C3520123	1	Space Ring Kit
⑪	NY10150017S	4	Nylock Nut

SOC 2512H CYLINDER

- 1.** After removing the protective caps of the fittings, manually center the rod of the cylinder body. For the center, “(L)” length should be 139.5mm.

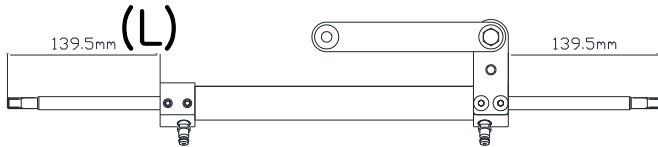

⚠ CAUTION

During this process an oil leak from the fittings can occur. This oil must not be discharged into the sea in any case.

- 2.** Position the engine straight so that its arm is perpendicular to the transom.

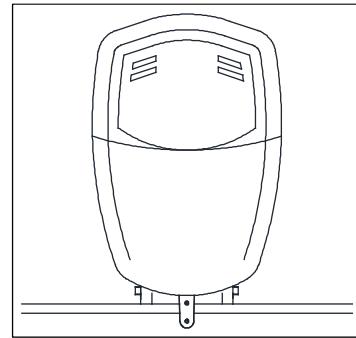

- 3.** Connect the cylinder plate to the engine steering arm by means of the bolt ①, and tighten this bolt with a torque 25[Nm] after insert the washer ③. Thread on the Lock nut ④ and tighten it with torque 15[Nm] after insert the washer ③.

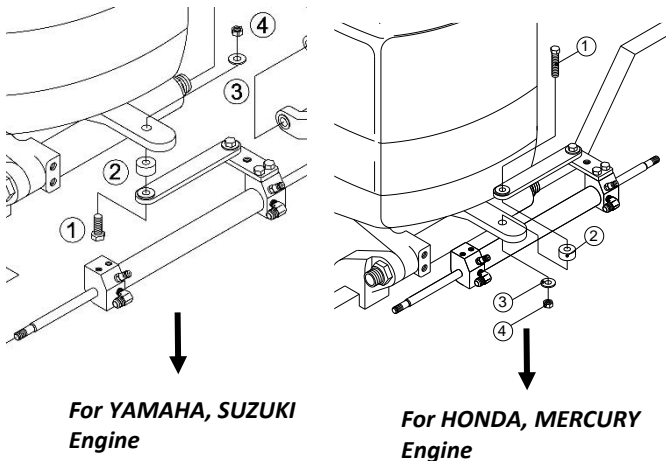

- 4.** Use the spacer ② if required.

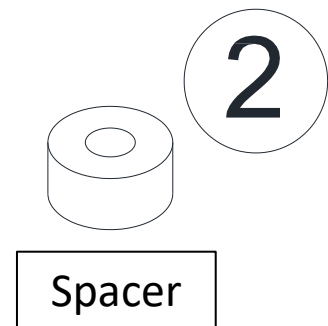

- 5.** Insert the Support Rod L ⑤ into the tilt tube.

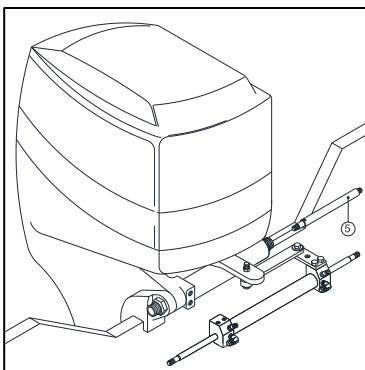

- ⚠ Grease the Support Rods ⑤ ⑥, by using marine grease to prevent the corrosion of the metal parts.**

- 6.** Combine Support Rod L ⑤ and R ⑥ by using both hands.

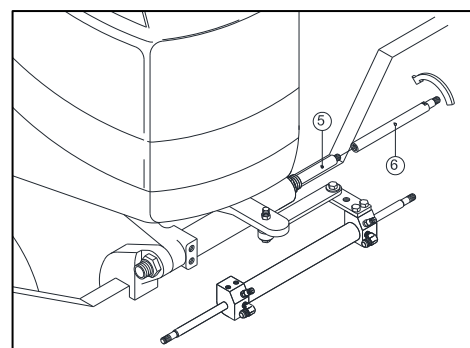

SOC 2512H CYLINDER

7. After insert the Support Rod R⑥, tighten it by monkey spanner. Holding the end of L⑤ and turning the end of R⑥.

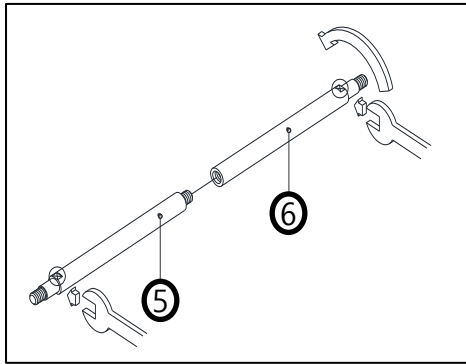

8. Insert the ADJ nut⑦ to the left part of the tilt tube. And then screw it until it comes into contact with the stop nut.

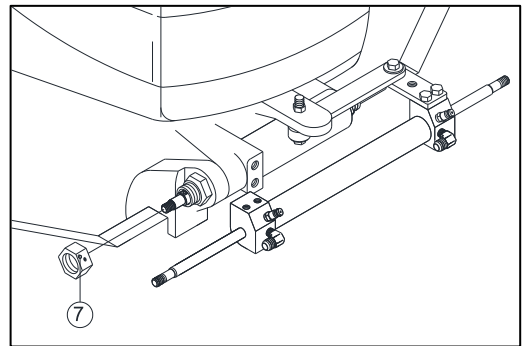

9. Insert the right and left arm. Then, Position the Plain washer⑨ as shown the picture.

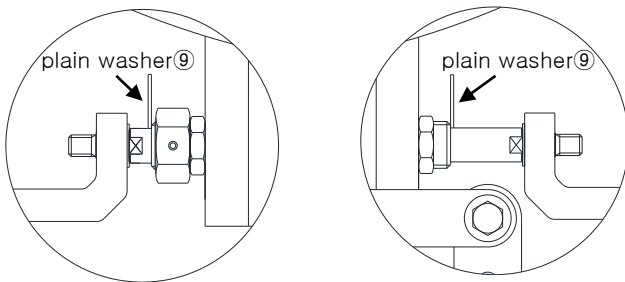

10. Measure the gap (d1) between Plain washer⑨ and arm.

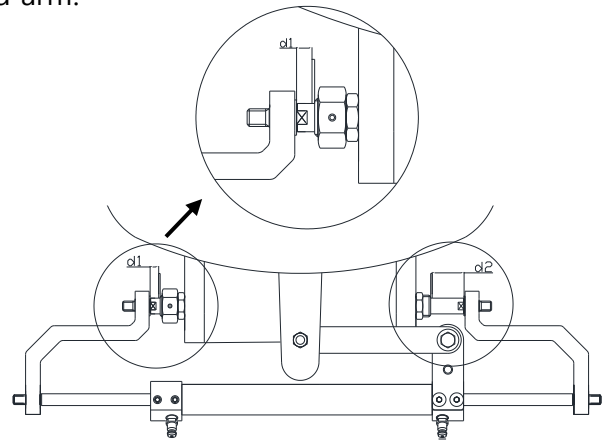

11. If d1 is less than 1mm, do not use any Space Ring. However, if it is more than 1mm, using the proper Space Ring ⑪ to fill up the gap.

⑪ Space Ring kit

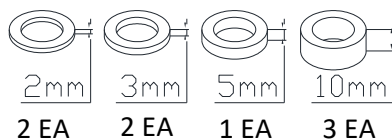

12. Measure the gap(d2) between Plain washer⑨ and Arm and choose the proper Space rings⑪ to fill the gap. Leave 1mm as maximum gap after choosing proper Space rings⑪ to make engine tilting easy. (Refer to the ' Example '. That will be useful formula when you choose Space ring).

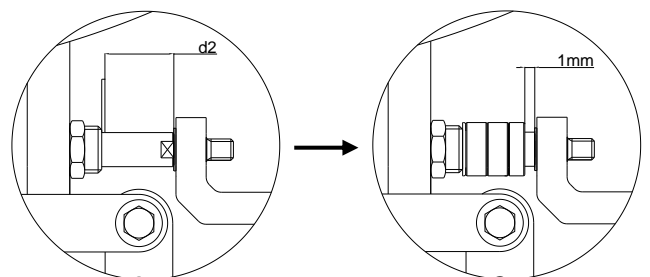

SOC 2512H CYLINDER

◆ Example

d2 = 21mm (Normal measurement)
- 1mm (Minimum space)

20mm

(You may need 2T+3T+5T+10T Space ring)

13. Once the correct Space Ring have been chosen for d1 and d2, remove the arm.

14. Insert the Plain washers⑨③ and correct Space Ring ⑪. Then, Insert the right and left arm⑧ as shown in the picture.

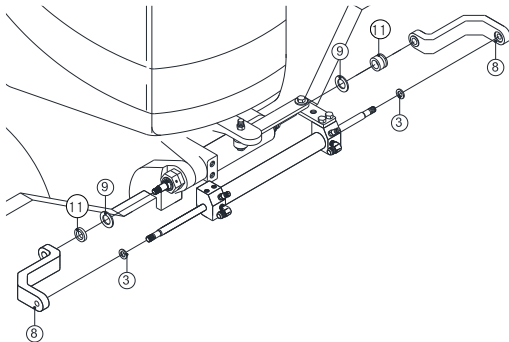

◆ NOTICE

Both the Plain washers⑨ must be positioned towards the tilt tube on the opposite side of the arm to avoid their wear during engine lifting and lowering.

15. Insert the washers③ on the ends of the support rod and cylinder rod. and tighten the nuts⑪ with a torque [70Nm] after greasing.

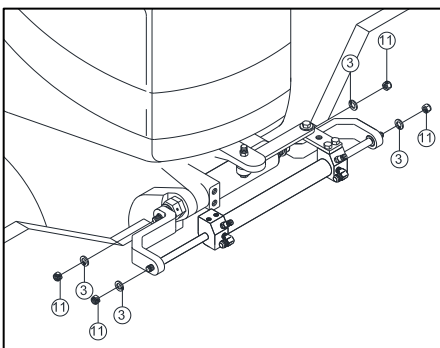

16. Screw the ADJ nut to the left side and bring it into contact with the Plain washer⑨, until clearance is eliminated.

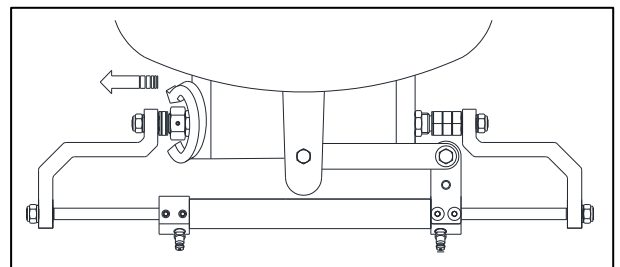

SOC 2512H CYLINDER

17. Tighten the set screw on ADJ nut with a 2mm allen key(hex key).

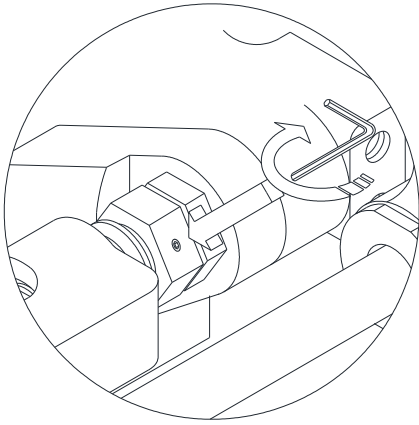

18. Check the correct cylinder installation by moving manually the engine on the right and on the left.

The rotation must be as symmetric as possible so that the steering angle is the same on both sides.

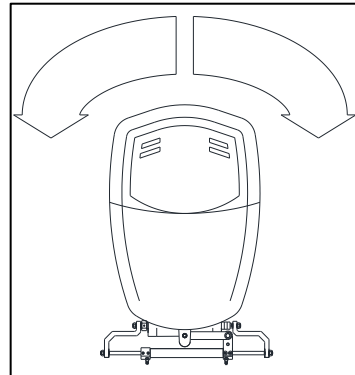

19. Check again in the correct engine movement both during the tilting.

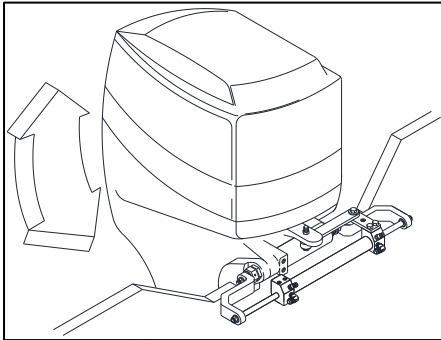

⚠ **WARNING**

In case of the any contact with the transom, stop the installation and contact the specialized staff.

Installation – Test Procedures

3-1) Test Procedures after Installation

Procedure	Test	Check Point
1. Leakage Test	For the test, apply a pressure on the cylinder, hose and helm pump by rotating steering wheel further at the end of steering.	<ul style="list-style-type: none"> •Helm pump : Two ports which oil come out •Hose : Hose couplings •Cylinder : Two ports which oil come out/in
2. Wheel turn	For the test, rotate steering wheel from left to right and count the wheel turn. Also count the wheel turn from right to left	Ideal wheel turn to achieve •18cc helm pump with SOC2512 cylinder : 4.6
3. Hose kinked	For the test, check the entire hose from helm pump to cylinder	
4. Cylinder interface	For the test, tilt up the engine fully. Check if any interference of cylinder , hose etc	

Installation – Oil Filling and bleeding

4-1) Oil Filling and Air Bleeding

These instructions show how to fill and purge the manual hydraulic steering system.

Incorrect oil supply or incorrect air-vent will cause helm-mans feel heavy of the steering wheel while rotation of the steering wheel and will cause a continuous wheel turn without stopping.

Recommend Hydraulic Fluid : ISO 15.

FILLING & PURGING

1. Filling & Purging Kit (OAK-300) includes

1) Oil coupler, Oil cap, transparent tube (600mm)

2) Transparent tube (1meter) for bleeding from cylinder

3) Push Pin

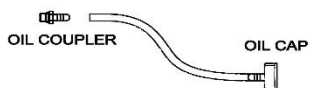

How to fill and Purge the system

①

1. Remove the oil plug (Keep it of reuse) from Helm pump.

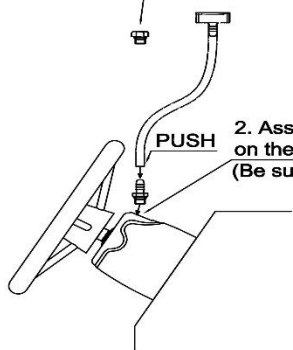

2. Assemble the Oil coupler with tight on the filler port of Helm pump. (Be sure no leak of air or oil)

②

5. Make 3–4 holes on the oil bottle by using Push pin like drawing.

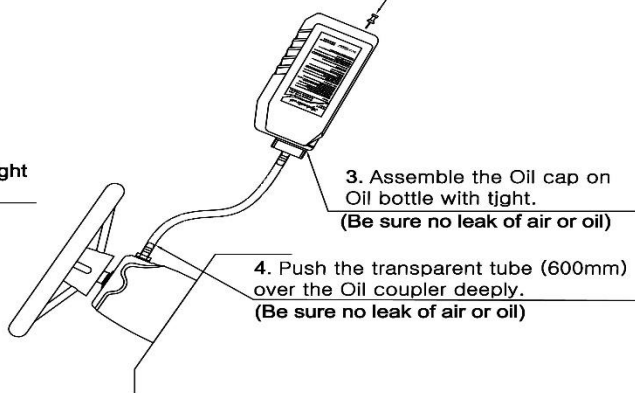

3. Assemble the Oil cap on Oil bottle with tight. (Be sure no leak of air or oil)

4. Push the transparent tube (600mm) over the Oil coupler deeply. (Be sure no leak of air or oil)

③

6. After Completing Filling & Purging, block Helm Pump with Oil Plug

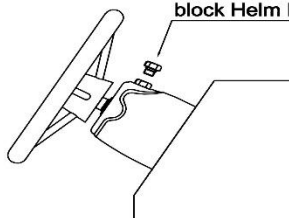

※ CAUTION

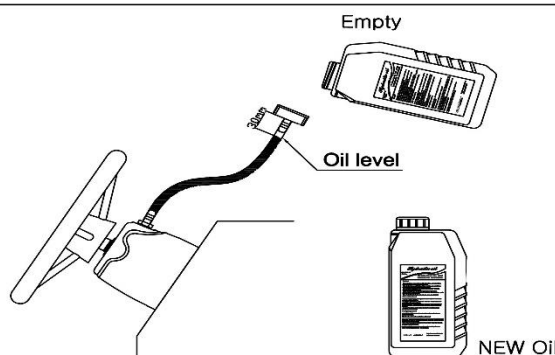

※ Caution
Do not let oil level fall down to 30mm from Oil cap while exchanging new oil bottle.

⚠ CAUTION

During the filling the oil, turn the steering wheel slowly. If you turn the steering wheel too fast, foam may grow in the oil. In this case you can continue the filling after 24 hours.

4. Oil Filling and Air Bleeding

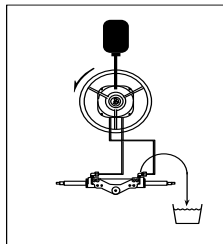

Step 2

Step 1 : Fill the helm pump full of oil.

Step 2 : Open the right bleeder.

Slowly turn steering wheel anti-clockwise until a steady stream of air free oil comes out of the right bleeder.

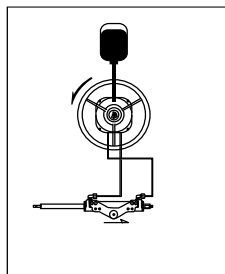

Step 3

Step 3 : Close the right bleeder. Continue to turn steering wheel anti-clockwise until the cylinder tube is fully moved on one side of the rod. Open the left bleeder

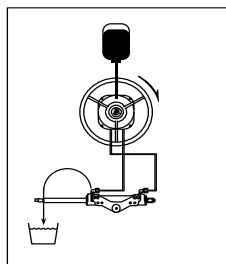

Step 4

Step 4 : Holding the cylinder tube (to prevent it from moving back) slowly turn the steering wheel clockwise until a steady stream of air free oil comes out of the left bleeder . While continuing to turn the wheel, close the left bleeder and let go of the cylinder tube.

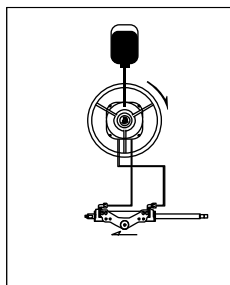

Step 5

Step 5 : Continue turning the steering wheel clockwise

until the cylinder tube is fully moved at other side of rod.

The steering wheel will come to a stop. Open right bleeder .

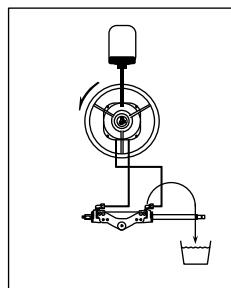

Step 6

Step 6 : Slowly turn the steering wheel anti-clockwise

until a steady stream of air free oil comes out of bleeder.

While continuing to turn the steering wheel, close the right bleeder.

Now, fill and purge is complete.

CAUTION

During the filling the oil, turn the steering wheel slowly. If you turn the steering wheel too fast, foam may grow in the oil. In this case you can continue the filling after 24 hours.

System Diagram –Single Station

1. SINGLE STATION

1-1 Single Station

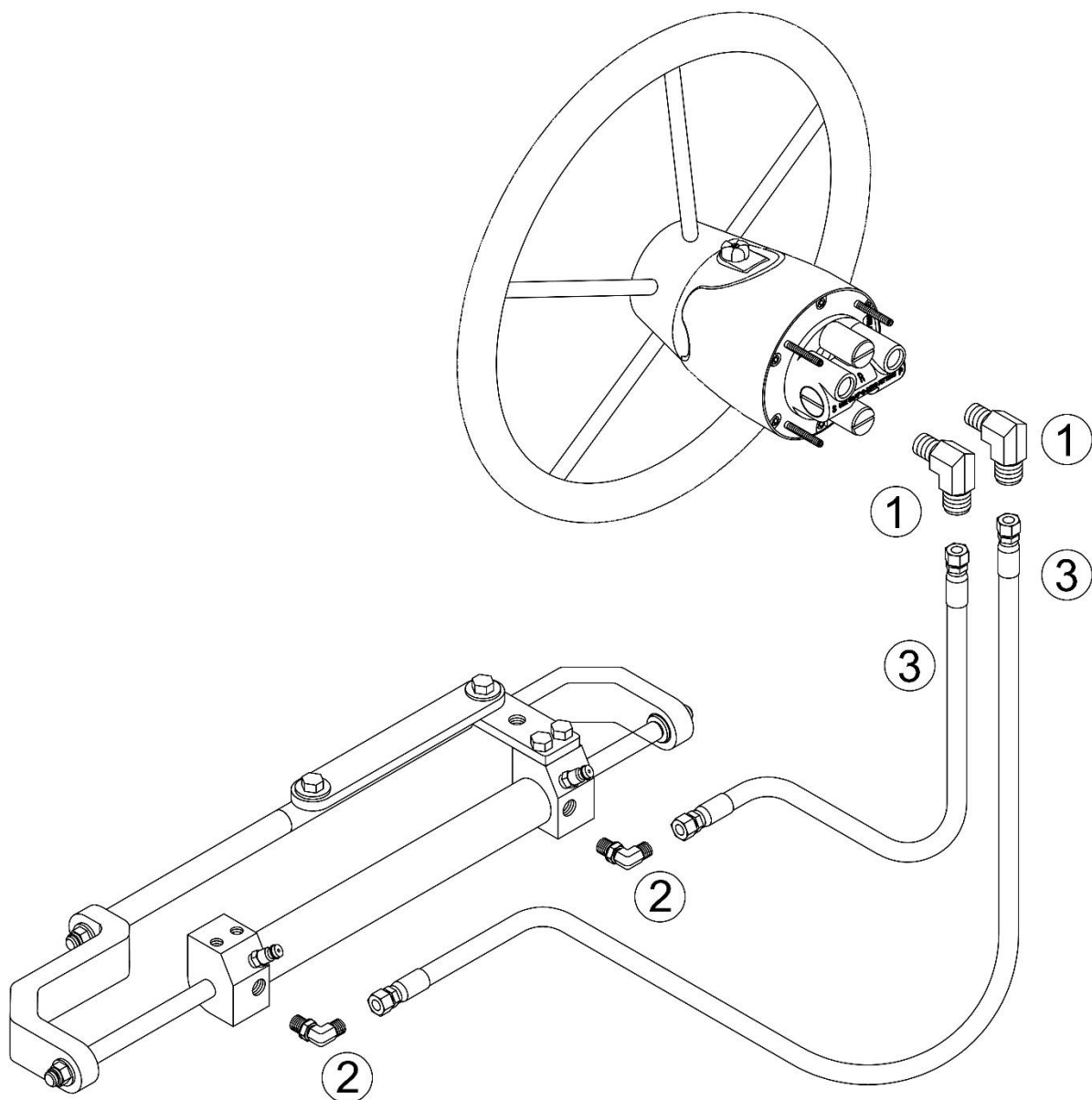

Fitting and Hoses For MO 100H

No	Part Number	Part Name	Q'TY	Remark
1	HLO14H0S	Elbow fitting (PF 1/4 Oring x PF 1/4)	2	Standard Supply in MO 100H package.
2	HLO14H0S	Elbow fitting (PF1/4 Oring x PF 1/4)	2	
3	NH04-SS-07	Hose 7M (PF 1/4 hose coupling)	2	

*Fittings & Hose specification could depend on market requirement

System Diagram – Dual Station

1. SINGLE ENGINE

1-1 Dual Station

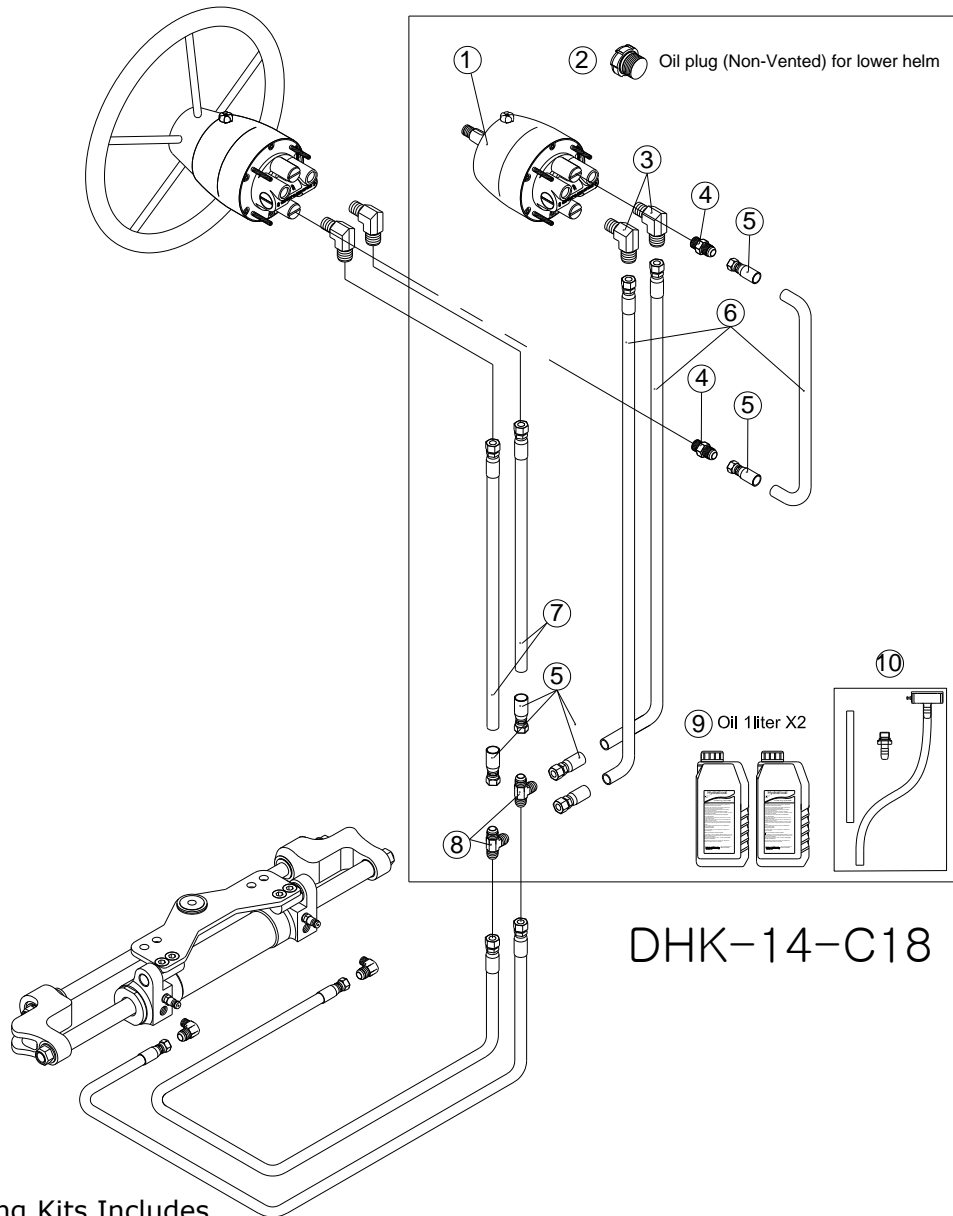

Dual Steering Kits Includes

No	Description	DUAL STATION ¼ DHK-14-C18	Q'TY
1	HELM PUMP	CSH018	1
2	CAP(Ø1)	C1800802	1
3	ELBOW FIITINGS	HLO14H0S	2
4	STRAIGHT FIITINGS	HSO14H0S	2
5	CAMPUKA	CPK0414	6
6	HOSE 30M	NH04-SS-30	1
7	HOSE 04M	NH04-SS-04	1
8	TEE FIITNGS	HTH300	2
9	OIL (1LITTER)	SF OIL 15	2
10	OIL ACCESSORIES KIT	OAK-300	1

⚠ CAUTION

Poor installation and maintenance may result in loss of steering and cause property damage and/or personal injury. Maintenance requirement change according to climate, frequency and the use. Inspections are necessary at least every year and must carry out by specialized marine mechanics. Check the cylinder fittings and the seals and the helm O-rings to prevent leaks. Replacement if necessary. To keep a suitable oil level in the helm pump, fill and bleed the system as described in the manual. Check the hose and entire system wear, the nut and bolt tightening every six months and make sure that they are not damaged.

Trouble Shooting

Description of failure	Cause of failure	Corrective action
There is some instability when the steering wheel is turned	Air remain	Repeat the air bleeding procedure
	Low oil level in the helm pump	Add the hydraulic oil
	Oil leak	Repair
Steering is hard to turn	The cylinder is not connected properly to the outboard engine	Check and correct the connecting area on the cylinder
	Interference or breakage of hoses and/or fittings	Check for any sharp bent of the hose, or interference and/or breakage on the hose fittings.
	Application of unauthorized hydraulic oil having higher viscosity	Replace the oil with SEAFIRST OIL or alternatively ISO # 15
	Failure of steering pivot shaft on the outboard engine	Contact your dealer for system inspection
Cylinder does not move in response to the steering wheel operation	Foreign matters stuck between the check valve and the seat in the helm pump	Contact your dealer for the check valve replacement
Cylinder returns to the initial position as the steering wheel stops its operation	Air remains in the system	Repeat the air bleeding procedure
	Foreign matters stuck between the check valve and the seat in the helm pump	Contact your dealer for the check valve replacement

Cleaning

Clean the system using water and non-abrasive soap



공장 : Seafirst Engineering Co
경남 김해시 진례면 테크노밸리로 137, 50875
전화 : 055 338 1640 팩스 : 055 338 1641
<http://www.seafirst.co.kr>